

# AFCO Installation & Operation Instructions

## Model #AF 969741 • Model 10 SS Bypass Airless Foamer / Sprayer

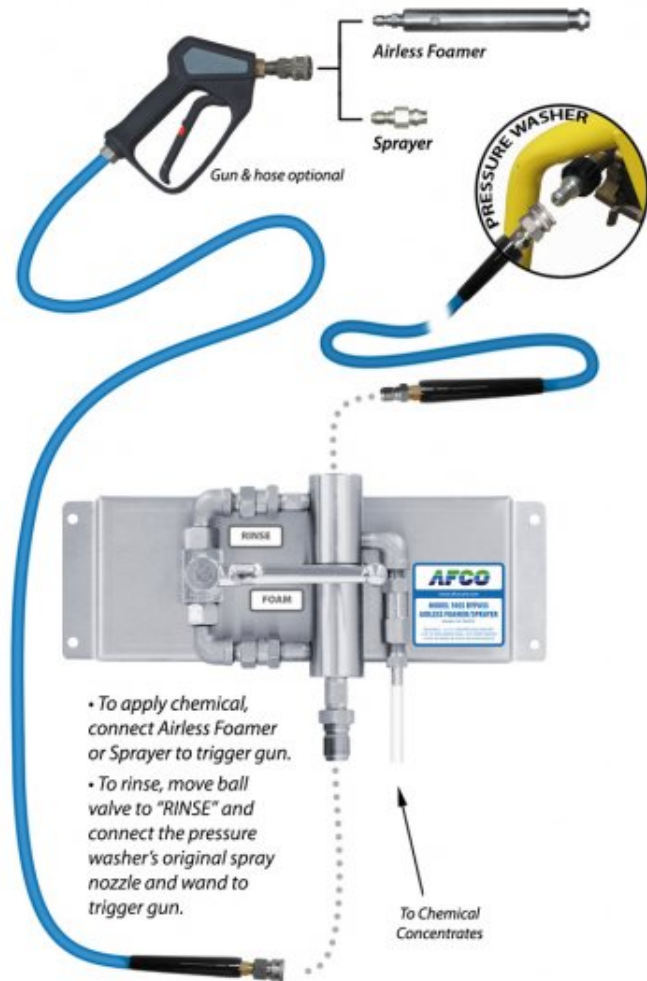

### REQUIREMENTS

#### Chemical Concentrate

<b>Water</b>	
Temperature	up to 180°F
Supply Line	1/2"

<b>Hose</b>	3/8" x 50'
-------------	------------

<b>Pressure Washer</b>	2.2 - 3.5 GPM
------------------------	---------------

### OPTIONS

<b>Large Stainless Steel Hose Rack</b>	# 224150
<b>Stainless Steel Jug Racks</b>	
2 ½ Gallon (8 ½" x 10 ½")	# 224210
5 Gallon (12" x 12")	# 224215
5 Gallon Round Locking	# 224216
<b>Lid &amp; Suction Hose for 1 &amp; 5 Gallon Pails</b>	
Pail Lid Suction Hose Assembly	# 709101



<http://www.afcocare.com>

**READ ALL  
INSTRUCTIONS BEFORE  
USING EQUIPMENT!**

## Overview

The Model 10 SS Bypass Airless Foamer/Sprayer is a high pressure wash/rinse system for quickly applying a foaming chemical and rinsing through the same hose. Using a 2.2 - 3.5 GPM pressure washer, this stainless steel venturi injection system draws and blends chemical concentrate into the water stream to create an accurately diluted solution. The solution is then projected through the discharge hose to the foam wand where it draws in atmospheric air to create a wet, clinging foam. Use the spray nozzle to apply non-foaming chemicals and simply open the bypass ball valve to rinse at full volume and pressure.



# Safety & Operational Precautions

- For proper performance do NOT modify, substitute nozzle, hose diameter or length.
- Manufacturer assumes no liability for the use or misuse of this unit.
- Wear protective clothing, gloves and eye wear when working with chemicals.
- Always direct the discharge away from people and electrical devices.
- Follow the chemical manufacturer's safe handling instructions.

## TO INSTALL (REFER TO DIAGRAM, NEXT PAGE.)

If you are connecting to a potable water supply follow all local codes for backflow prevention.

1. Mount the unit to a suitable surface above the chemical supply to prevent siphoning.
2. Connect the discharge hose(s) as shown in the diagram.
3. Flush any new plumbing of debris before connecting water.
4. Connect water supply. If water piping is older, or has known contaminants, install a water filter.

Set the chemical dilution ratio by threading one of the color coded metering tips into each chemical check valve. See chemical labels for dilution ratio recommendation or consult your chemical supplier.

- For the strongest dilution ratio do NOT install a colored metering tip.
- The dilution ratios in the metering tip chart are based on water thin chemicals with a viscosity of 1CPS.
- **Thicker chemicals will require a larger tip than the ratios shown in the chart.**
- Application results will ultimately determine final tip color.
- Select the tip color that is closest to your desired chemical strength and thread it into the tip holder. DO NOT OVER TIGHTEN.
- Push the chemical tube over the check valve barb and place the strainer in the chemical concentrate.

## TO OPERATE

### TO FOAM

1. Two nozzles are included with the foam wand: The fan nozzle provides a wide pattern for faster coverage. The 0° nozzle provides increased foam throw distance. Install the preferred nozzle.
2. Remove the rinse nozzle and quick connect the foam wand to your trigger gun as shown in the diagram. If your trigger gun doesn't have quick disconnects you will have to install them.
3. Close the by-pass ball valve.
4. Hold the trigger gun firmly and direct the discharge in a safe direction. Pull the trigger and begin application.
5. Make final metering tip adjustments based on application results. Try the next larger sized metering tip until the results are acceptable.

### TO SPRAY

1. Quick connect the spray nozzle to your trigger gun as shown in the diagram.
2. Close the by-pass ball valve.
3. Hold the trigger gun firmly and direct the discharge in a safe direction. Pull the trigger and begin application.

### TO RINSE

1. When foaming or spraying is completed, release the trigger.
2. Replace the airless foamer or spray nozzle with the rinse nozzle.
3. Open the by-pass ball valve.
4. Rinse the work surface as you normally would and rinse before the chemical dries.
5. If the foamer /sprayer will not be used for a period of time it is BEST to draw fresh water through the pick up tube to prevent chemical from drying inside the components.

### Metering Tip Selection Chart

Metering Tip Color	Oz. per Min.	Example: Dilution Ratio @ 3.5 GPM
Brown	.56	800:1
Clear	.88	509:1
Bright Purple	1.38	325:1
White	2.15	208:1
Pink	2.93	153:1
Corn Yellow	3.84	117:1
Dark Green	4.88	92:1
Orange	5.77	78:1
Gray	6.01	75:1
Light Green	7.01	64:1
Med. Green	8.06	56:1
Clear Pink	9.43	48:1
Yellow Green	11.50	39:1
Burgundy	11.93	38:1
Pale Pink	13.87	32:1
Light Blue	15.14	30:1
Dark Purple	17.88	25:1
Navy Blue	25.36	18:1
Clear Aqua	28.60	16:1
Black	50.00	9:1
No Tip	-	5.0:1

The dilution ratios above are approximate values. Due to chemical viscosity, actual dilution ratios may vary.

### Flow Rate Chart

Water Flow Rate
GPM
2.2
3.0
<b>3.5</b>

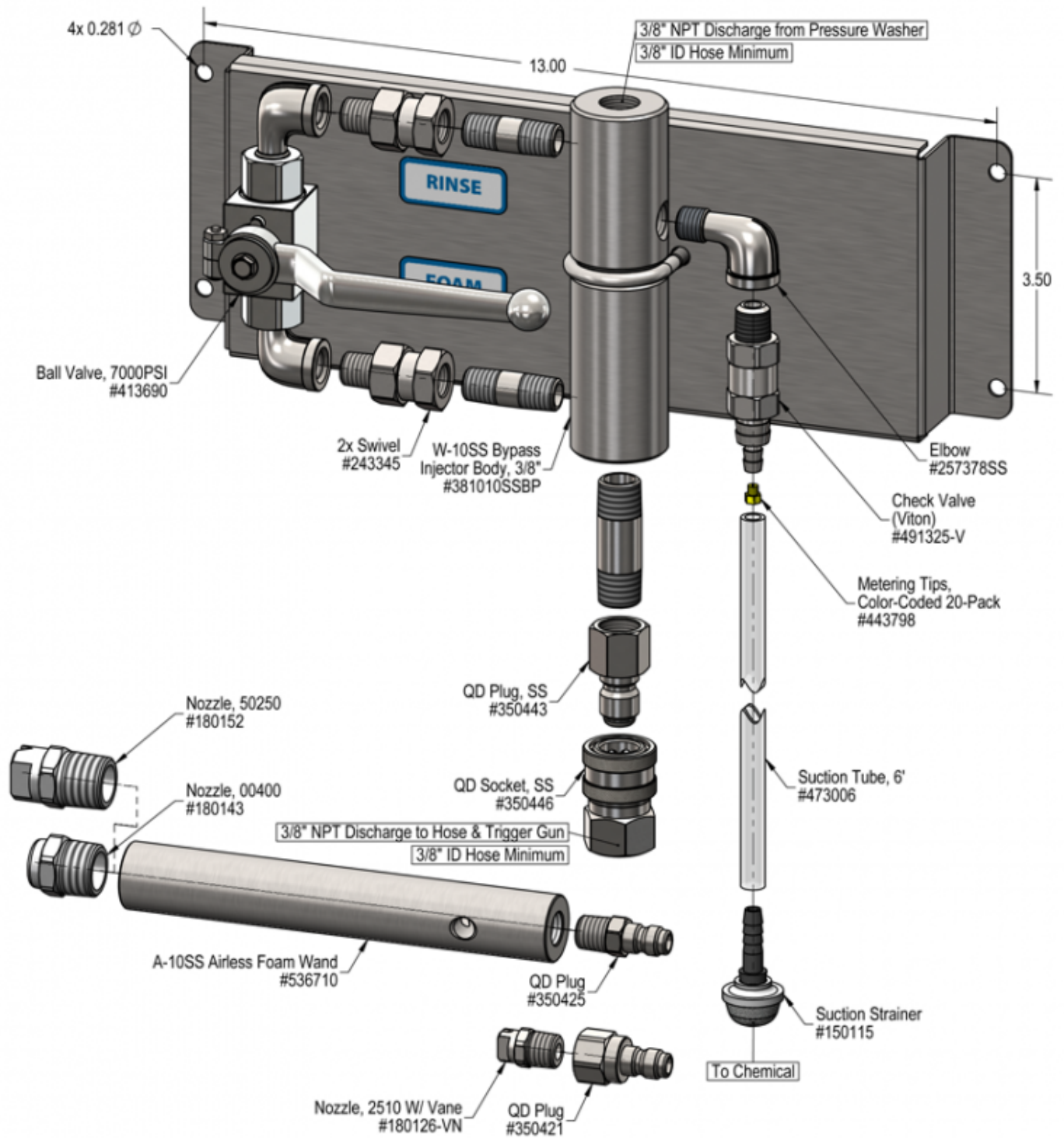

# Troubleshooting Guide

## AF 969741 • Model 10 SS Bypass Airless Foamer / Sprayer

Problem	Possible Cause / Solution	
	Startup	Maintenance
A) Unit will not draw chemical.	1, 2, 3, 7	8, 9, 10, 11, 12, 13
B) Does not foam properly	1, 4, 6	8, 9, 11, 12
C) Using too much chemical	5	

Possible Cause / Solution	
Startup	Maintenance
<ol style="list-style-type: none"> <li>1. <b>Water volume too low</b> <ul style="list-style-type: none"> <li>◦ See requirements.</li> </ul> </li> <li>2. <b>Water inlet clogged</b> <ul style="list-style-type: none"> <li>◦ Clean the water inlet. DO NOT DRILL OUT</li> </ul> </li> <li>3. <b>Hose size too small</b> <ul style="list-style-type: none"> <li>◦ MUST be 3/8" ID hose minimum</li> </ul> </li> <li>4. <b>Ensure chemical is recommended for foaming and/or the application</b> <ul style="list-style-type: none"> <li>◦ See chemical manufacturer.</li> </ul> </li> <li>5. <b>Dilution too weak / Chemical is very thick.</b> <ul style="list-style-type: none"> <li>◦ Install larger metering tip or remove metering tip.</li> </ul> </li> <li>6. <b>Dilution too strong / No metering tip installed or wrong metering tip installed</b> <ul style="list-style-type: none"> <li>◦ Install a metering tip or install a smaller metering tip</li> </ul> </li> <li>7. <b>Hose too long</b> <ul style="list-style-type: none"> <li>◦ Use a shorter discharge hose to alleviate back pressure on the injector</li> <li>◦ The allowable length of hose varies based on individual pressure washers and equipment setups</li> </ul> </li> </ol>	<ol style="list-style-type: none"> <li>8. <b>Chemical check valve stuck, clogged, loose or failed</b> <ul style="list-style-type: none"> <li>◦ Clean, tighten or rebuild.</li> </ul> </li> <li>9. <b>Chemical strainer or metering tip blocked</b> <ul style="list-style-type: none"> <li>◦ Clean or replace chemical strainer and/or metering tip.</li> </ul> </li> <li>10. <b>Chemical tube stretched out where tube slides over check valve or pin hole/cut in chemical tube (sucking air in) which reduces chemical intake. Chemical tube not immersed in chemical or depleted</b> <ul style="list-style-type: none"> <li>◦ Cut off end of tube, replace tube or immerse tube in chemical</li> </ul> </li> <li>11. <b>Discharge nozzle is wrong size</b> <ul style="list-style-type: none"> <li>◦ Install correct nozzle (see parts drawing).</li> </ul> </li> <li>12. <b>Chemical build-up or hard water scale may have formed in the foam wand or injector body causing poor or no chemical pick-up</b> <ul style="list-style-type: none"> <li>◦ Follow Preventive Maintenance instructions below, using hot water and/or descaling acid. When there is no draw at all, carefully remove inlet fitting and chemical check valve. Soak injector body and or foam wand in de-scaling acid.</li> </ul> </li> <li>13. <b>By-Pass ball valve open. (By-pass models only)</b> <ul style="list-style-type: none"> <li>◦ Close by-pass valve.</li> </ul> </li> </ol>

**PREVENTIVE MAINTENANCE: When the unit will be out of service for extended periods, place chemical tube(s) in water and flush the chemical out of the unit to help prevent chemical from drying out and causing build-up. Periodically check and clean chemical strainer and replace if missing.**

